

Strong-Bolt® 2 Design Information — Concrete

Carbon Steel Strong-Bolt® 2 Installation Information¹

Characteristic	Symbol	Units	Nominal Anchor Diameter, d_a (in.)											
			$\frac{1}{4}$ ⁴	$\frac{3}{8}$ ⁵		$\frac{1}{2}$ ⁵		$\frac{5}{8}$ ⁵		$\frac{3}{4}$ ⁵		1 ⁵		
Installation Information														
Nominal Diameter	d_a	in.	$\frac{1}{4}$	$\frac{3}{8}$		$\frac{1}{2}$		$\frac{5}{8}$		$\frac{3}{4}$		1		
Drill Bit Diameter	d	in.	$\frac{1}{4}$	$\frac{3}{8}$		$\frac{1}{2}$		$\frac{5}{8}$		$\frac{3}{4}$		1		
Baseplate Clearance Hole Diameter ²	d_c	in.	$\frac{5}{16}$	$\frac{7}{16}$		$\frac{9}{16}$		$\frac{11}{16}$		$\frac{7}{8}$		$1\frac{1}{8}$		
Installation Torque	T_{inst}	ft-lbf	4	30		60		90		150		230		
Nominal Embedment Depth	h_{nom}	in.	$1\frac{3}{4}$	$1\frac{7}{8}$	$2\frac{7}{8}$	$2\frac{3}{4}$	$3\frac{7}{8}$	$3\frac{3}{8}$	$5\frac{1}{8}$	$4\frac{1}{8}$	$5\frac{3}{4}$	$5\frac{1}{4}$	$9\frac{3}{4}$	
Effective Embedment Depth	h_{ef}	in.	$1\frac{1}{2}$	$1\frac{1}{2}$	$2\frac{1}{2}$	$2\frac{1}{4}$	$3\frac{3}{8}$	$2\frac{3}{4}$	$4\frac{1}{2}$	$3\frac{3}{8}$	5	$4\frac{1}{2}$	9	
Minimum Hole Depth	h_{hole}	in.	$1\frac{7}{8}$	2	3	3	$4\frac{1}{8}$	$3\frac{5}{8}$	$5\frac{3}{8}$	$4\frac{3}{8}$	6	$5\frac{1}{2}$	10	
Minimum Overall Anchor Length	ℓ_{anch}	in.	$2\frac{1}{4}$	$2\frac{3}{4}$	$3\frac{1}{2}$	$3\frac{3}{4}$	$5\frac{1}{2}$	$4\frac{1}{2}$	6	$5\frac{1}{2}$	7	7	13	
Critical Edge Distance	c_{ac}	in.	$2\frac{1}{2}$	$6\frac{1}{2}$	6	$6\frac{1}{2}$	$6\frac{1}{2}$	$7\frac{1}{2}$	$7\frac{1}{2}$	9	9	8	18	$13\frac{1}{2}$
Minimum Edge Distance	c_{min}	in.	$1\frac{3}{4}$	6		7	4	4	$6\frac{1}{2}$		$6\frac{1}{2}$		8	
	for $s \geq$	in.	—	—		—	—	—	—		8		—	
Minimum Spacing	s_{min}	in.	$2\frac{1}{4}$	3		7	4	4	5		7		8	
	for $c \geq$	in.	—	—		—	—	—	—		—		—	
Minimum Concrete Thickness	h_{min}	in.	$3\frac{1}{4}$	$3\frac{1}{4}$	$4\frac{1}{2}$	$4\frac{1}{2}$	$5\frac{1}{2}$	6	$5\frac{1}{2}$	$7\frac{7}{8}$	$6\frac{3}{4}$	$8\frac{3}{4}$	9	$13\frac{1}{2}$
Additional Data														
Yield Strength	f_{ya}	psi	56,000	92,000		85,000				70,000		60,000		
Tensile Strength	f_{uta}	psi	70,000	115,000				110,000		78,000				
Minimum Tensile and Shear Stress Area	A_{se}	in. ²	0.0318	0.0514		0.105		0.166		0.270		0.472		
Axial Stiffness in Service Load Range — Cracked and Uncracked Concrete	β	lb./in.	73,700 ³	34,820		63,570		91,370		118,840		299,600		

1. The information presented in this table is to be used in conjunction with the design criteria of ACI 318 Appendix D.

2. The clearance must comply with applicable code requirements for the connected element.

3. The tabulated value of β for $\frac{1}{4}$ -inch diameter carbon steel Strong-Bolt 2 anchor is for installations in uncracked concrete only.

4. The $\frac{1}{4}$ -inch-diameter (6.4mm) anchor may be installed in top of uncracked normal-weight and sand-lightweight concrete over profile steel deck, where concrete thickness above upper flute meets the minimum thickness specified in this table.

5. The $\frac{3}{8}$ -inch-through 1-inch-diameter (9.5mm through 25.4mm) anchors may be installed in top of cracked and uncracked normal-weight and sand-lightweight concrete over profile steel deck, where concrete thickness above upper flute meets the minimum thickness specified in this table.

Strong-Bolt® 2 Design Information — Concrete

Stainless-Steel Strong-Bolt® 2 Installation Information¹

Characteristic	Symbol	Units	Nominal Anchor Diameter, d_a (in.)									
			$\frac{1}{4}$ ⁴		$\frac{3}{8}$ ⁵		$\frac{1}{2}$ ⁵		$\frac{5}{8}$ ⁵		$\frac{3}{4}$ ⁵	
Installation Information												
Nominal Diameter	d_a	in.	$\frac{1}{4}$		$\frac{3}{8}$		$\frac{1}{2}$		$\frac{5}{8}$		$\frac{3}{4}$	
Drill Bit Diameter	d	in.	$\frac{1}{4}$		$\frac{3}{8}$		$\frac{1}{2}$		$\frac{5}{8}$		$\frac{3}{4}$	
Baseplate Clearance Hole Diameter ²	d_c	in.	$\frac{5}{16}$		$\frac{7}{16}$		$\frac{9}{16}$		$\frac{11}{16}$		$\frac{7}{8}$	
Installation Torque	T_{inst}	ft-lbf	4		30		60		80		150	
Nominal Embedment Depth	h_{nom}	in.	$1\frac{3}{4}$		$1\frac{7}{8}$ $2\frac{7}{8}$		$2\frac{3}{4}$ $3\frac{7}{8}$		$3\frac{3}{8}$ $5\frac{1}{8}$		$4\frac{1}{8}$ $5\frac{3}{4}$	
Effective Embedment Depth	h_{ef}	in.	$1\frac{1}{2}$		$1\frac{1}{2}$ $2\frac{1}{2}$		$2\frac{1}{4}$ $3\frac{3}{8}$		$2\frac{3}{4}$ $4\frac{1}{2}$		$3\frac{3}{8}$ 5	
Minimum Hole Depth	h_{hole}	in.	$1\frac{7}{8}$		2 3		3 $4\frac{1}{8}$		$3\frac{5}{8}$ $5\frac{3}{8}$		$4\frac{3}{8}$ 6	
Minimum Overall Anchor Length	ℓ_{anch}	in.	$2\frac{1}{4}$		$2\frac{3}{4}$ $3\frac{1}{2}$		$3\frac{3}{4}$ $5\frac{1}{2}$		$4\frac{1}{2}$ 6		$5\frac{1}{2}$ 7	
Critical Edge Distance	c_{ac}	in.	$2\frac{1}{2}$		$6\frac{1}{2}$ $8\frac{1}{2}$		$4\frac{1}{2}$ 7		$7\frac{1}{2}$ 9		8 8	
Minimum Edge Distance	c_{min}	in.	$1\frac{3}{4}$		6		$6\frac{1}{2}$ 5 4		4		6	
	for $s \geq$	in.	—		10		— — 8		8		—	
Minimum Spacing	s_{min}	in.	$2\frac{1}{4}$		3		8 $5\frac{1}{2}$ 4		$6\frac{1}{4}$		$6\frac{1}{2}$	
	for $c \geq$	in.	—		10		— 8		$5\frac{1}{2}$		—	
Minimum Concrete Thickness	h_{min}	in.	$3\frac{1}{4}$		$3\frac{1}{4}$ $4\frac{1}{2}$		$4\frac{1}{2}$ 6		$5\frac{1}{2}$ $7\frac{7}{8}$		$6\frac{3}{4}$ $8\frac{3}{4}$	
Additional Data												
Yield Strength	f_{ya}	psi	96,000		80,000		92,000		82,000		68,000	
Tensile Strength	f_{uta}	psi	120,000		100,000		115,000		108,000		95,000	
Minimum Tensile and Shear Stress Area	A_{se}	in. ²	0.0255		0.0514		0.105		0.166		0.270	
Axial Stiffness in Service Load Range — Cracked and Uncracked Concrete	β	lb./in.	54,430 ³		29,150		54,900		61,270		154,290	

1. The information presented in this table is to be used in conjunction with the design criteria of ACI 318 Appendix D.

2. The clearance must comply with applicable code requirements for the connected element.

3. The tabulated value of β for $\frac{1}{4}$ -inch diameter stainless steel Strong-Bolt 2 anchor is for installations in uncracked concrete only.

4. The $\frac{1}{4}$ -inch-diameter (6.4mm) anchor may be installed in top of uncracked normal-weight and sand-lightweight concrete over profile steel deck, where concrete thickness above upper flute meets the minimum thickness specified in this table.

5. The $\frac{3}{8}$ -inch-through $\frac{3}{4}$ -inch-diameter (9.5mm through 19.1mm) anchors may be installed in top of cracked and uncracked normal-weight and sand-lightweight concrete over profile steel deck, where concrete thickness above upper flute meets the minimum thickness specified in this table.

Strong-Bolt® 2 Design Information — Concrete

Carbon Steel Strong-Bolt® 2 Tension Strength Design Data¹

Characteristic	Symbol	Units	Nominal Anchor Diameter, d_a (in.)										
			$\frac{1}{4}^8$	$\frac{3}{8}^9$	$\frac{1}{2}^9$	$\frac{5}{8}^9$	$\frac{3}{4}^9$	1^9					
Anchor Category	1, 2 or 3	—	1										2
Nominal Embedment Depth	h_{nom}	in.	$1\frac{1}{4}$	$1\frac{1}{8}$	$2\frac{1}{8}$	$2\frac{1}{4}$	$3\frac{1}{8}$	$3\frac{1}{2}$	$5\frac{1}{8}$	$4\frac{1}{2}$	$5\frac{3}{4}$	$5\frac{1}{4}$	$9\frac{3}{4}$
Steel Strength in Tension (ACI 318 Section D.5.1)													
Steel Strength in Tension	N_{sa}	lb.	2,225	5,600	12,100	19,070	29,700	36,815					
Strength Reduction Factor — Steel Failure ²	ϕ_{sa}	—	0.75										0.65
Concrete Breakout Strength in Tension (ACI 318 Section D.5.2)¹⁰													
Effective Embedment Depth	h_{ef}	in.	$1\frac{1}{2}$	$1\frac{1}{2}$	$2\frac{1}{2}$	$2\frac{1}{4}$	$3\frac{3}{8}$	$2\frac{3}{4}$	$4\frac{1}{2}$	$3\frac{3}{4}$	5	$4\frac{1}{2}$	9
Critical Edge Distance	c_{ac}	in.	$2\frac{1}{2}$	$6\frac{1}{2}$	6	$6\frac{1}{2}$	$7\frac{1}{2}$	$7\frac{1}{2}$	9	9	8	18	$13\frac{1}{2}$
Effectiveness Factor — Uncracked Concrete	k_{uncr}	—	24										
Effectiveness Factor — Cracked Concrete	k_{cr}	—	— ⁷										
Modification Factor	$\psi_{c,N}$	—	— ⁷										
Strength Reduction Factor — Concrete Breakout Failure ³	ϕ_{cb}	—	0.65										0.55
Pullout Strength in Tension (ACI 318 Section D.5.3)¹⁰													
Pullout Strength, Cracked Concrete ($f'_c=2,500$ psi)	$N_{p,cr}$	lb.	— ⁷	1,300 ⁵	2,775 ⁵	N/A ⁴	3,735 ⁵	N/A ⁴	6,985 ⁵	N/A ⁴	8,500 ⁵	7,700 ⁵	11,185 ⁵
Pullout Strength, Uncracked Concrete ($f'_c=2,500$ psi)	$N_{p,uncr}$	lb.	N/A ⁴	N/A ⁴	3,340 ⁵	3,615 ⁵	5,255 ⁵	N/A ⁴	9,025 ⁵	7,115 ⁵	8,870 ⁵	8,360 ⁵	9,690 ⁵
Strength Reduction Factor — Pullout Failure ⁶	ϕ_p	—	0.65										0.55
Tensile Strength for Seismic Applications (ACI 318 Section D.3.3.)¹⁰													
Tension Strength of Single Anchor for Seismic Loads ($f'_c=2,500$ psi)	$N_{p,eq}$	lb.	— ⁷	1,300 ⁵	2,775 ⁵	N/A ⁴	3,735 ⁵	N/A ⁴	6,985 ⁵	N/A ⁴	8,500 ⁵	7,700 ⁵	11,185 ⁵
Strength Reduction Factor — Pullout Failure ⁶	ϕ_{eq}	—	0.65										0.55

- The information presented in this table must be used in conjunction with the design criteria of ACI 318 Appendix D, except as modified below.
- The tabulated value of ϕ_{sa} applies when the load combinations of Section 1605.2.1 of the IBC or ACI 318 Section 9.2 are used. If the load combinations of ACI 318 Appendix C are used, the appropriate value of ϕ_{sa} must be determined in accordance with ACI 318 D.4.4. Strong-Bolt 2 anchors are ductile steel elements as defined in ACI 318 D.1.
- The tabulated value of ϕ_{cb} applies when both the load combinations of Section 1605.2.1 of the IBC or ACI 318 Section 9.2 are used and the requirements of ACI 318 D.4.3(c) for Condition B are met. Condition B applies where supplementary reinforcement is not provided. For installations where complying supplementary reinforcement can be verified, the ϕ_{cb} factors described in ACI 318 D.4.3 for Condition A are allowed. If the load combinations of ACI 318 Section 9.2 are used and the requirements of ACI 318 Section D.4.3 for Condition A are met, the appropriate value of ϕ_{cb} must be determined in accordance with ACI 318 D.4.3(c). If the load combinations of ACI 318 Appendix C are used, the appropriate value of ϕ_{cb} must be determined in accordance with ACI 318 D.4.4(c).
- N/A (not applicable) denotes that pullout resistance does not need to be considered.
- The characteristic pullout strength for greater concrete compressive strengths shall be increased by multiplying the tabular value by $(f'_c/2,500 \text{ psi})^{0.5}$.
- The tabulated value of ϕ_p or ϕ_{eq} applies when the load combinations of Section 1605.2.1 of the IBC or ACI 318 Section 9.2 are used and the requirements of ACI 318 D.4.3(c) for Condition B are met. If the load combinations of ACI 318 Appendix C are used, appropriate value of ϕ must be determined in accordance with ACI 318 Section D.4.4(c).
- The $\frac{1}{4}$ -inch diameter carbon steel Strong-Bolt 2 anchor installation in cracked concrete is beyond the scope of this report.
- The $\frac{1}{4}$ -inch diameter (6.4mm) anchor may be installed in top of uncracked normal-weight and sand-lightweight concrete over profile steel deck, where concrete thickness above upper flute meets the minimum thickness specified in the table on page 146.
- The $\frac{3}{8}$ -inch through 1-inch diameter (9.5mm through 25.4mm) anchors may be installed in top of cracked and uncracked normal-weight and sand-lightweight concrete over profile steel deck, where concrete thickness above upper flute meets the minimum thickness specified in the table on page 146.
- For sand-lightweight concrete, in lieu of ACI 318 Section D.3.6, modify the value of concrete breakout strength $N_{p,cr}$, $N_{p,uncr}$ and N_{eq} by 0.6. All-lightweight concrete is beyond the scope of this table.

* See page 12 for an explanation of the load table icons.

Strong-Bolt® 2 Design Information — Concrete

Stainless-Steel Strong-Bolt® 2 Tension Strength Design Data¹



Characteristic	Symbol	Units	Nominal Anchor Diameter, d_a (in.)									
			1/4" ¹⁰	3/8" ¹¹	1/2"	5/8"	3/4"	1"	1 1/8"	1 1/4"	1 3/8"	1 1/2"
Anchor Category	1, 2 or 3	—	1									
Nominal Embedment Depth	h_{nom}	in.	1 3/4	1 7/8	2 1/8	2 3/8	2 7/8	3 1/8	3 3/8	3 7/8	4 1/8	4 3/4
Steel Strength in Tension (ACI 318 Section D.5.1)												
Steel Strength in Tension	N_{sa}	lb.	3,060	5,140	12,075	17,930	25,650					
Strength Reduction Factor — Steel Failure ²	ϕ_{sa}	—	0.75									
Concrete Breakout Strength in Tension (ACI 318 Section D.5.2)¹²												
Effective Embedment Depth	h_{ef}	in.	1 1/2	1 1/2	2 1/2	2 1/4	3 3/8	2 3/4	4 1/2	3 3/8	5	
Critical Edge Distance	c_{ac}	in.	2 1/2	6 1/2	8 1/2	4 1/2	7	7 1/2	9	8	8	
Effectiveness Factor — Uncracked Concrete	k_{uncr}	—	24									
Effectiveness Factor — Cracked Concrete	k_{cr}	—	— ⁹									
Modification Factor	$\psi_{c,N}$	—	— ⁹									
Strength Reduction Factor — Concrete Breakout Failure ³	ϕ_{cb}	—	0.65									
Pullout Strength in Tension (ACI 318 Section D.5.3)¹²												
Pullout Strength, Cracked Concrete ($f'_c=2,500$ psi)	$N_{p,cr}$	lb.	— ⁹	1,720 ⁶	3,145 ⁶	2,560 ⁵	4,305 ⁵	N/A ⁴	6,545 ⁷	N/A ⁴	8,230 ⁵	
Pullout Strength, Uncracked Concrete ($f'_c=2,500$ psi)	$N_{p,uncr}$	lb.	1,925 ⁷	N/A ⁴	4,770 ⁶	3,230 ⁵	4,495 ⁵	N/A ⁴	7,615 ⁷	7,725 ⁷	9,625 ⁷	
Strength Reduction Factor — Pullout Failure ⁸	ϕ_p	—	0.65									
Tensile Strength for Seismic Applications (ACI 318 Section D.3.3.)¹²												
Tension Strength of Single Anchor for Seismic Loads ($f'_c=2,500$ psi)	$N_{p,eq}$	lb.	— ⁹	1,720 ⁶	2,830 ⁶	2,560 ⁵	4,305 ⁵	N/A ⁴	6,545 ⁷	N/A ⁴	8,230 ⁵	
Strength Reduction Factor — Pullout Failure ⁸	ϕ_{eq}	—	0.65									

- The information presented in this table must be used in conjunction with the design criteria of ACI 318 Appendix D, except as modified below.
- The tabulated value of ϕ_{sa} applies when the load combinations of Section 1605.2.1 of the IBC or ACI 318 Section 9.2 are used, if the load combinations of ACI 318 Appendix C are used, the appropriate value of ϕ_{sa} must be determined in accordance with ACI 318 D.4.4. Strong-Bolt 2 anchors are ductile steel elements as defined in ACI 318 D.1.
- The tabulated value of ϕ_{cb} applies when both the load combinations of Section 1605.2.1 of the IBC or ACI 318 Section 9.2 are used and the requirements of ACI 318 D.4.3(c) for Condition B are met. Condition B applies where supplementary reinforcement is not provided. For installations where complying supplementary reinforcement can be verified, the ϕ_{cb} factors described in ACI 318 D.4.3 for Condition A are allowed. If the load combinations of ACI 318 Section 9.2 are used and the requirements of ACI 318 Section D.4.3 for Condition A are met, the appropriate value of ϕ_{cb} must be determined in accordance with ACI 318 D.4.3(c). If the load combinations of ACI 318 Appendix C are used, the appropriate value of ϕ_{cb} must be determined in accordance with ACI 318 D.4.4(c).
- N/A (not applicable) denotes that pullout resistance does not need to be considered.
- The characteristic pullout strength for greater concrete compressive strengths shall be increased by multiplying the tabular value by $(f'_c/2,500 \text{ psi})^{0.5}$.
- The characteristic pullout strength for greater concrete compressive strengths shall be increased by multiplying the tabular value by $(f'_c/2,500 \text{ psi})^{0.3}$.
- The characteristic pullout strength for greater concrete compressive strengths shall be increased by multiplying the tabular value by $(f'_c/2,500 \text{ psi})^{0.4}$.
- The tabulated value of ϕ_p or ϕ_{eq} applies when the load combinations of Section 1605.2.1 of the IBC or ACI 318 Section 9.2 are used and the requirements of ACI 318 D.4.3(c) for Condition B are met. If the load combinations of ACI 318 Appendix C are used, appropriate value of ϕ must be determined in accordance with ACI 318 Section D.4.4(c).
- The 1/4-inch diameter stainless steel Strong-Bolt 2 anchor installation in cracked concrete is beyond the scope of this report.
- The 1/4-inch diameter (6.4mm) anchor may be installed in top of uncracked normal-weight and sand-lightweight concrete over profile steel deck, where concrete thickness above upper flute meets the minimum thickness specified in the table on page 147.
- The 3/8-inch through 3/4-inch diameter (9.5mm through 19.1mm) anchors may be installed in top of cracked and uncracked normal-weight and sand-lightweight concrete over profile steel deck, where concrete thickness above upper flute meets the minimum thickness specified in the table on page 147.
- For sand-lightweight concrete, in lieu of ACI 318 Section D.3.6, modify the value of concrete breakout strength $N_{p,cr}$, $N_{p,uncr}$ and N_{eq} by 0.6. All-lightweight concrete is beyond the scope of this table.

* See page 12 for an explanation of the load table icons.

Strong-Bolt® 2 Design Information — Concrete

Carbon Steel Strong-Bolt® 2 Shear Strength Design Data¹

Characteristic	Symbol	Units	Nominal Anchor Diameter, d_a (in.)										
			$\frac{1}{4}^6$	$\frac{3}{8}^7$	$\frac{1}{2}^7$	$\frac{5}{8}^7$	$\frac{3}{4}^7$	1^7					
Anchor Category	1, 2 or 3	—	1									2	
Nominal Embedment Depth	h_{nom}	in.	1 $\frac{3}{4}$	1 $\frac{7}{8}$	2 $\frac{7}{8}$	2 $\frac{3}{4}$	3 $\frac{7}{8}$	3 $\frac{3}{8}$	5 $\frac{1}{8}$	4 $\frac{1}{8}$	5 $\frac{3}{4}$	5 $\frac{1}{4}$	9 $\frac{3}{4}$
Steel Strength in Shear (ACI 318 Section D.6.1)													
Steel Strength in Shear	V_{sa}	lb.	965	1,800	7,235	11,035	14,480	15,020					
Strength Reduction Factor — Steel Failure ²	ϕ_{sa}	—	0.65									0.60	
Concrete Breakout Strength in Shear (ACI 318 Section D.6.2)⁸													
Outside Diameter	d_a	in.	0.25	0.375	0.500	0.625	0.750	1.00					
Load-Bearing Length of Anchor in Shear	ℓ_e	in.	1.500	1.500	2.500	2.250	3.375	2.750	4.500	3.375	5.000	4.500	8.000
Strength Reduction Factor — Concrete Breakout Failure ²	ϕ_{cb}	—	0.70										
Concrete Pryout Strength in Shear (ACI 318 Section D.6.3)													
Coefficient for Pryout Strength	k_{cp}	—	1.0	2.0	1.0	2.0							
Effective Embedment Depth	h_{ef}	in.	1 $\frac{1}{2}$	1 $\frac{1}{2}$	2 $\frac{1}{2}$	2 $\frac{1}{4}$	3 $\frac{3}{8}$	2 $\frac{3}{4}$	4 $\frac{1}{2}$	3 $\frac{3}{8}$	5	4 $\frac{1}{2}$	9
Strength Reduction Factor — Concrete Pryout Failure ⁴	ϕ_{cp}	—	0.70										
Steel Strength in Shear for Seismic Applications(ACI 318 Section D.3.3.)													
Shear Strength of Single Anchor for Seismic Loads ($f'_c=2,500$ psi)	$V_{sa,eq}$	lb.	— ⁵	1,800	6,510	9,930	11,775	15,020					
Strength Reduction Factor — Steel Failure ²	ϕ_{sa}	—	0.65									0.60	

- The information presented in this table must be used in conjunction with the design criteria of ACI 318 Appendix D, except as modified below.
- The tabulated value of ϕ_{sa} applies when the load combinations of Section 1605.2.1 of the IBC or ACI 318 Section 9.2 are used and the requirements of ACI 318 D.4.3(c) for Condition B are met. If the load combinations of ACI 318 Appendix C are used, the appropriate value of ϕ_{sa} must be determined in accordance with ACI 318 D.4.4. Strong-Bolt 2 anchors are ductile steel elements as defined in ACI 318 D.1.
- The tabulated value of ϕ_{cb} applies when both the load combinations of Section 1605.2.1 of the IBC or ACI 318 Section 9.2 are used and the requirements of ACI 318 D.4.3(c) for Condition B are met. Condition B applies where supplementary reinforcement is not provided. For installations where complying supplementary reinforcement can be verified, the ϕ_{cb} factors described in ACI 318 D.4.3 for Condition A are allowed. If the load combinations of ACI 318 Section 9.2 are used and the requirements of ACI 318 Section D.4.3 for Condition A are met, the appropriate value of ϕ_{cb} must be determined in accordance with ACI 318 D.4.3(c). If the load combinations of ACI 318 Appendix C are used, the appropriate value of ϕ_{cb} must be determined in accordance with ACI 318 D.4.4(c).
- The tabulated value of ϕ_{cp} applies when both the load combinations of ACI 318 Section 9.2 are used and the requirements of ACI 318 D.4.3(c) for Condition B are met. If the load combinations of ACI 318 Appendix C are used, appropriate value of ϕ_{cp} must be determined in accordance with ACI 318 Section D.4.4(c).
- The $\frac{1}{4}$ -inch diameter carbon steel Strong-Bolt 2 anchor installation in cracked concrete is beyond the scope of this report.
- The $\frac{1}{4}$ -inch diameter (6.4mm) anchor may be installed in top of uncracked normal-weight and sand-lightweight concrete over profile steel deck, where concrete thickness above upper flute meets the minimum thickness specified in the table on page 146.
- The $\frac{3}{8}$ -inch through 1-inch diameter (9.5mm through 25.4mm) anchors may be installed in top of cracked and uncracked normal-weight and sand-lightweight concrete over profile steel deck, where concrete thickness above upper flute meets the minimum thickness specified in the table on page 146.
- For sand-lightweight concrete, in lieu of ACI 318 Section D.3.6, modify the value of concrete breakout by 0.6. All-lightweight concrete is beyond the scope of this table.

* See page 12 for an explanation of the load table icons.

Strong-Bolt® 2 Design Information — Concrete

Stainless-Steel Strong-Bolt® 2 Shear Strength Design Data¹

Characteristic	Symbol	Units	Nominal Anchor Diameter, d_a (in.)									
			$\frac{1}{4}$ ⁶	$\frac{3}{8}$ ⁷	$\frac{1}{2}$ ⁷	$\frac{5}{8}$ ⁷	$\frac{3}{4}$ ⁷					
Anchor Category	1, 2 or 3	—	1									
Nominal Embedment Depth	h_{nom}	in.	1¾	1⅞	2⅞	2¾	3⅞	3¾	5⅞	4⅞	5¾	
Steel Strength in Shear (ACI 318 Section D.6.1)												
Steel Strength in Shear	V_{sa}	lb.	1,605	3,085	7,245	6,745	10,760	15,045				
Strength Reduction Factor — Steel Failure ²	ϕ_{sa}	—	0.65									
Concrete Breakout Strength in Shear (ACI 318 Section D.6.2)⁸												
Outside Diameter	d_a	in.	0.250	0.375	0.500	0.625	0.750					
Load Bearing Length of Anchor in Shear	ℓ_e	in.	1.500	1.500	2.500	2.250	3.375	2.750	4.500	3.375	5.000	
Strength Reduction Factor — Concrete Breakout Failure ³	ϕ_{cb}	—	0.70									
Concrete Pryout Strength in Shear (ACI 318 Section D.6.3)												
Coefficient for Pryout Strength	k_{cp}	—	1.0	2.0	1.0	2.0						
Effective Embedment Depth	h_{ef}	in.	1½	1½	2½	2¼	3¾	2¾	4½	3¾	5	
Strength Reduction Factor — Concrete Pryout Failure ⁴	ϕ_{cp}	—	0.70									
Steel Strength in Shear for Seismic Applications (ACI 318 Section D.3.3.)												
Shear Strength of Single Anchor for Seismic Loads ($f'_c=2,500$ psi)	$V_{sa,eq}$	lb.	— ⁵	3,085	6,100	6,745	10,760	13,620				
Strength Reduction Factor — Steel Failure ²	ϕ_{sa}	—	0.65									

- The information presented in this table must be used in conjunction with the design criteria of ACI 318 Appendix D, except as modified below.
- The tabulated value of ϕ_{sa} applies when the load combinations of Section 1605.2.1 of the IBC or ACI 318 Section 9.2 are used and the requirements of ACI 318 D.4.3(c) Condition B are met. If the load combinations of ACI 318 Appendix C are used, the appropriate value of ϕ_{sa} must be determined in accordance with ACI 318 D.4.3.(c) for Strong-Bolt 2 anchors are ductile steel elements as defined in ACI 318 D.1.
- The tabulated value of ϕ_{cb} applies when both the load combinations of Section 1605.2.1 of the IBC or ACI 318 Section 9.2 are used and the requirements of ACI 318 D.4.3(c) for Condition B are met. Condition B applies where supplementary reinforcement is not provided. For installations where complying supplementary reinforcement can be verified, the ϕ_{cb} factors described in ACI 318 D.4.3 for Condition A are allowed. If the load combinations of ACI 318 Section 9.2 are used and the requirements of ACI 318 Section D.4.3 for Condition A are met, the appropriate value of ϕ_{cb} must be determined in accordance with ACI 318 D.4.3.(c). If the load combinations of ACI 318 Appendix C are used, the appropriate value of ϕ_{cb} must be determined in accordance with ACI 318 D.4.4.(c).
- The tabulated value of ϕ_{cp} applies when both the load combinations of ACI 318 Section 9.2 are used and the requirements of ACI 318 D.4.3(c) for Condition B are met. If the load combinations of ACI 318 Appendix C are used, appropriate value of ϕ_{cp} must be determined in accordance with ACI 318 Section D.4.4.(c).
- The ¼-inch diameter stainless-steel Strong-Bolt 2 anchor installation in cracked concrete is beyond the scope of this report.
- The ¼-inch diameter (6.4mm) anchor may be installed in top of uncracked normal-weight and sand-lightweight concrete over profile steel deck, where concrete thickness above upper flute meets the minimum thickness specified in the table on page 147.
- The ⅜-inch through ¾-inch diameter (9.5mm through 19.1mm) anchors may be installed in top of cracked and uncracked normal-weight and sand-lightweight concrete over profile steel deck, where concrete thickness above upper flute meets the minimum thickness specified in the table on page 147.
- For sand-lightweight concrete, in lieu of ACI 318 Section D.3.6, modify the value of concrete breakout by 0.6. All-lightweight concrete is beyond the scope of this table.

* See page 12 for an explanation of the load table icons.

Strong-Bolt® 2 Design Information — Concrete

Carbon Steel Strong-Bolt® 2 Information for Installation in the Topside of Concrete-Filled Profile Steel Deck Floor and Roof Assemblies^{1,2,3,4}



Design Information	Symbol	Units	Nominal Anchor Diameter (in.)	
			3/8	1/2
Nominal Embedment Depth	h_{nom}	in.	1 7/8	2 3/4
Effective Embedment Depth	h_{ef}	in.	1 1/2	2 1/4
Minimum Concrete Thickness ⁵	$h_{min,deck}$	in.	2 1/2	3 1/4
Critical Edge Distance	$c_{ac,deck,top}$	in.	4 3/4	4
Minimum Edge Distance	$c_{min,deck,top}$	in.	4 3/4	4 1/2
Minimum Spacing	$s_{min,deck,top}$	in.	7	6 1/2

For SI: 1 inch = 25.4mm; 1 lbf = 4.45N

1. Installation must comply with the table on page 146 and Figure 1 below.
2. Design capacity shall be based on calculations according to values in the tables on pages 148 and 150.
3. Minimum flute depth (distance from top of flute to bottom of flute) is 1 1/2 inches.
4. Steel deck thickness shall be a minimum 20 gauge.
5. Minimum concrete thickness ($h_{min,deck}$) refers to concrete thickness above upper flute.

Stainless-Steel Strong-Bolt® 2 Information for Installation in the Topside of Concrete-Filled Profile Steel Deck Floor and Roof Assemblies^{1,2,3,4}



Design Information	Symbol	Units	Nominal Anchor Diameter (in.)	
			3/8	1/2
Nominal Embedment Depth	h_{nom}	in.	1 7/8	2 3/4
Effective Embedment Depth	h_{ef}	in.	1 1/2	2 1/4
Minimum Concrete Thickness ⁵	$h_{min,deck}$	in.	2 1/2	3 1/4
Critical Edge Distance	$c_{ac,deck,top}$	in.	4 3/4	4
Minimum Edge Distance	$c_{min,deck,top}$	in.	4 3/4	6
Minimum Spacing	$s_{min,deck,top}$	in.	6 1/2	8

For SI: 1 inch = 25.4mm; 1 lbf = 4.45N

1. Installation must comply with the table on page 147 and Figure 1 below.
2. Design capacity shall be based on calculations according to values in the tables on pages 149 and 151.
3. Minimum flute depth (distance from top of flute to bottom of flute) is 1 1/2 inches.
4. Steel deck thickness shall be a minimum 20 gauge.
5. Minimum concrete thickness ($h_{min,deck}$) refers to concrete thickness above upper flute.

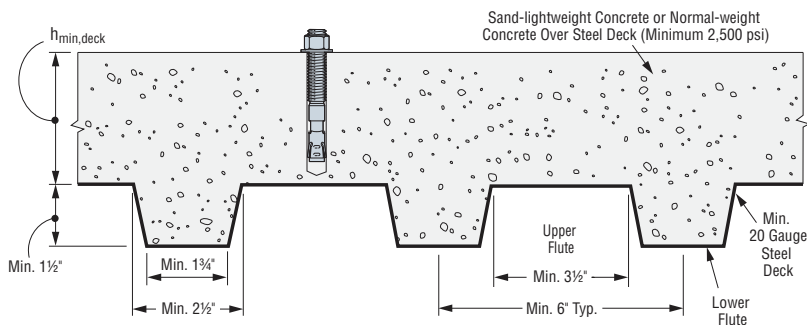

Figure 1

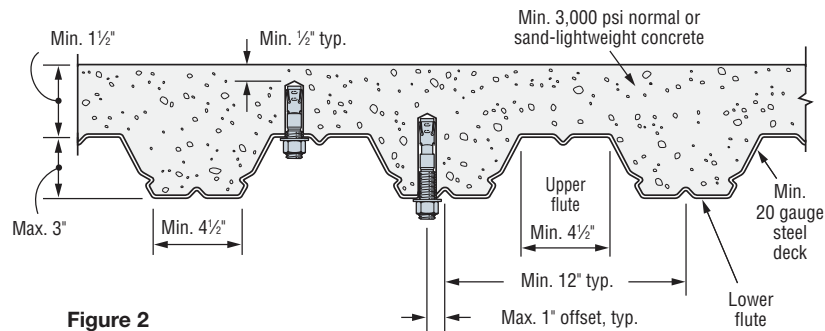
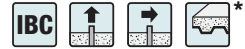

Figure 2

* See page 12 for an explanation of the load table icons.

Strong-Bolt® 2 Design Information — Concrete

Carbon Steel Strong-Bolt® 2 Tension and Shear Strength Design
Data for the Soffit of Concrete over Profile Steel Deck Floor and Roof Assemblies^{1,2,6,8,9}



Characteristic	Symbol	Units	Nominal Anchor Diameter (in.)								
			Carbon Steel								
			Lower Flute					Upper Flute			
			3/8	1/2	5/8	3/4	3/8	1/2			
Nominal Embedment Depth	h_{nom}	in.	2	3 3/8	2 3/4	4 1/2	3 3/8	5 5/8	4 1/8	2	2 3/4
Effective Embedment Depth	h_{ef}	in.	1 5/8	3	2 1/4	4	2 3/4	5	3 3/8	1 5/8	2 1/4
Installation Torque	T_{inst}	ft.-lbf.	30		60		90		150	30	60
Pullout Strength, concrete on metal deck (cracked) ^{3,4}	$N_{p,deck,cr}$	lb.	1,040 ⁷	2,615 ⁷	2,040 ⁷	2,730 ⁷	2,615 ⁷	4,990 ⁷	2,815 ⁷	1,340 ⁷	3,785 ⁷
Pullout Strength, concrete on metal deck (uncracked) ^{3,4}	$N_{p,deck,uncr}$	lb.	1,765 ⁷	3,150 ⁷	2,580 ⁷	3,840 ⁷	3,685 ⁷	6,565 ⁷	3,800 ⁷	2,275 ⁷	4,795 ⁷
Pullout Strength, concrete on metal deck (seismic) ^{3,4}	$N_{p,deck,eq}$	lb.	1,040 ⁷	2,615 ⁷	2,040 ⁷	2,730 ⁷	2,615 ⁷	4,990 ⁷	2,815 ⁷	1,340 ⁷	3,785 ⁷
Steel Strength in Shear, concrete on metal deck ⁵	$V_{sa,deck}$	lb.	1,595	3,490	2,135	4,580	2,640	7,000	4,535	3,545	5,920
Steel Strength in Shear, concrete on metal deck (seismic) ⁵	$V_{sa,deck,eq}$	lb.	1,595	3,490	1,920	4,120	2,375	6,300	3,690	3,545	5,330

- The information presented in this table must be used in conjunction with the design criteria of ACI 318 Appendix D, except as modified below.
- Profile steel deck must comply with the configuration in Figure 2 on the previous page, and have a minimum base-steel thickness of 0.035 inch [20 gauge]. Steel must comply with ASTM A 653/A 653M SS Grade 33 with minimum yield strength of 33,000 psi. Concrete compressive strength shall be 3,000 psi minimum.
- For anchors installed in the soffit of sand-lightweight or normal-weight concrete over metal deck floor and roof assemblies, calculation of the concrete breakout strength may be omitted.
- In accordance with ACI 318 Section D.5.3.2, the nominal pullout strength in cracked concrete for anchors installed in the soffit of sand-lightweight or normal-weight concrete over metal deck floor and roof assemblies $N_{p,deck,cr}$ shall be substituted for $N_{p,cr}$. Where analysis indicates no cracking at service loads, the normal pullout strength in uncracked concrete $N_{p,deck,uncr}$ shall be substituted for $N_{p,uncr}$. For seismic loads, $N_{p,deck,eq}$ shall be substituted for $N_{p,cr}$.
- In accordance with ACI 318 Section D.6.1.2(c), the shear strength for anchors installed in the soffit of sand-lightweight or normal-weight concrete over metal deck floor and roof assemblies $V_{sa,deck}$ shall be substituted for V_{sa} . For seismic loads, $V_{sa,deck,eq}$ shall be substituted for V_{sa} .
- The minimum anchor spacing along the flute must be the greater of $3.0h_{ef}$ or 1.5 times the flute width.
- The characteristic pull-out strength for greater concrete compressive strengths shall be increased by multiplying the tabular value by $(f'_c / 3,000 \text{ psi})^{0.5}$.
- Concrete shall be normal-weight or structural sand-lightweight concrete having a minimum specified compressive strength, f'_c , of 3,000 psi.
- Minimum distance to edge of panel is $2h_{ef}$.

Mechanical Anchors

Stainless Steel Strong-Bolt® 2 Tension and Shear Strength Design Data
for the Soffit of Concrete over Profile Steel Deck Floor and Roof Assemblies^{1,2,6,10,11}

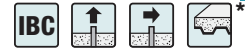

Characteristic	Symbol	Units	Stainless Steel								
			Lower Flute								
			Lower Flute					Upper Flute			
			3/8	1/2	5/8	3/4	3/8	1/2			
Nominal Embedment Depth	h_{nom}	in.	2	3 3/8	2 3/4	4 1/2	3 3/8	5 5/8	4 1/8	2	2 3/4
Effective Embedment Depth	h_{ef}	in.	1 5/8	3	2 1/4	4	2 3/4	5	3 3/8	1 5/8	2 1/4
Installation Torque	T_{inst}	ft.-lbf.	30		60		80		150	30	60
Pullout Strength, concrete on metal deck (cracked) ³	$N_{p,deck,cr}$	lb.	1,230 ⁸	2,605 ⁸	1,990 ⁷	2,550 ⁷	1,750 ⁹	4,020 ⁹	3,030 ⁷	1,550 ⁸	2,055 ⁷
Pullout Strength, concrete on metal deck (uncracked) ³	$N_{p,deck,uncr}$	lb.	1,580 ⁸	3,950 ⁸	2,475 ⁷	2,660 ⁷	2,470 ⁷	5,000 ⁷	4,275 ⁹	1,990 ⁸	2,560 ⁷
Pullout Strength, concrete on metal deck (seismic) ⁵	$N_{p,deck,eq}$	lb.	1,230 ⁸	2,345 ⁸	1,990 ⁷	2,550 ⁷	1,750 ⁹	4,020 ⁹	3,030 ⁷	1,550 ⁸	2,055 ⁷
Steel Strength in Shear, concrete on metal deck ⁴	$V_{sa,deck}$	lb.	2,285	3,085	3,430	4,680	3,235	5,430	6,135	3,085	5,955
Steel Strength in Shear, concrete on metal deck (seismic) ⁵	$V_{sa,deck,eq}$	lb.	2,285	3,085	2,400	3,275	3,235	5,430	5,520	3,085	4,170

- The information presented in this table must be used in conjunction with the design criteria of ACI 318 Appendix D, except as modified below.
- Profile steel deck must comply with the configuration in Figure 2 on the previous page, and have a minimum base-steel thickness of 0.035 inch [20 gauge]. Steel must comply with ASTM A 653/A 653M SS Grade 33 with minimum yield strength of 33,000 psi. Concrete compressive strength shall be 3,000 psi minimum.
- For anchors installed in the soffit of sand-lightweight or normal-weight concrete over metal deck floor and roof assemblies, calculation of the concrete breakout strength may be omitted.
- In accordance with ACI 318 Section D.5.3.2, the nominal pullout strength in cracked concrete for anchors installed in the soffit of sand-lightweight or normal-weight concrete over metal deck floor and roof assemblies $N_{p,deck,cr}$ shall be substituted for $N_{p,cr}$. Where analysis indicates no cracking at service loads, the normal pullout strength in uncracked concrete $N_{p,deck,uncr}$ shall be substituted for $N_{p,uncr}$. For seismic loads, $N_{p,deck,eq}$ shall be substituted for $N_{p,cr}$.
- In accordance with ACI 318 Section D.6.1.2(c), the shear strength for anchors installed in the soffit of sand-lightweight or normal-weight concrete over metal deck floor and roof assemblies $V_{sa,deck}$ shall be substituted for V_{sa} . For seismic loads, $V_{sa,deck,eq}$ shall be substituted for V_{sa} .
- The minimum anchor spacing along the flute must be the greater of $3.0h_{ef}$ or 1.5 times the flute width.
- The characteristic pull-out strength for greater concrete compressive strengths shall be increased by multiplying the tabular value by $(f'_c / 3,000 \text{ psi})^{0.5}$.
- The characteristic pull-out strength for greater concrete compressive strengths shall be increased by multiplying the tabular value by $(f'_c / 3,000 \text{ psi})^{0.3}$.
- The characteristic pull-out strength for greater concrete compressive strengths shall be increased by multiplying the tabular value by $(f'_c / 3,000 \text{ psi})^{0.4}$.
- Concrete shall be normal-weight or structural sand-lightweight concrete having a minimum specified compressive strength, f'_c , of 3,000 psi.
- Minimum distance to edge of panel is $2h_{ef}$.

* See page 12 for an explanation of the load table icons.

Strong-Bolt® 2 Design Information — Concrete

Carbon Steel Strong-Bolt® 2 Tension Design Strengths
in Normal-Weight Concrete ($f'_c = 2,500$ psi)

Anchor Dia. (in.)	Nominal Embed. Depth (in.)	Min. Concrete Thickness h_{min} (in.)	Critical Edge Distance c_{ac} (in.)	Minimum Edge Distance c_{min} (in.)	Tension Design Strength (lb.)							
					Edge Distances = c_{ac} on all sides				Edge Distances = c_{min} on one side and c_{ac} on three sides			
					SDC A-B ⁵		SDC C-F ^{6,7}		SDC A-B ⁵		SDC C-F ^{6,7}	
					Uncracked	Cracked	Uncracked	Cracked	Uncracked	Cracked	Uncracked	Cracked
1/4	1 3/4	3 1/4	2 1/2	1 3/4	1,435	—	—	—	1,070	—	—	—
3/8	1 7/8	3 1/4	6 1/2	6	1,435	845	1,075	635	1,325	845	990	635
	2 7/8	4 1/2	6	6	2,170	1,805	1,630	1,355	2,170	1,805	1,630	1,355
1/2	2 3/4	4 1/2	7	7	2,350	1,865	1,760	1,400	2,350	1,865	1,760	1,400
	3 7/8	6	7 1/2	4	3,415	2,430	2,560	1,820	2,740	2,430	2,055	1,820
5/8	3 3/8	5 1/2	7 1/2	6 1/2	3,555	2,520	2,665	1,890	3,085	2,520	2,310	1,890
	5 1/8	7 7/8	9	6 1/2	5,865	4,480	4,400	3,360	5,420	4,480	4,065	3,360
3/4	4 1/8	6 3/4	9	6 1/2	4,625	3,425	3,470	2,570	3,495	3,425	2,620	2,570
	5 3/4	8 3/4	8	6 1/2	5,765	5,525	4,325	4,145	5,765	5,525	4,325	4,145
1	5 1/4	9	18	8	4,600	4,235	3,450	3,175	2,800	4,235	2,100	3,175
	9 3/4	13 1/2	13 1/2	8	5,330	6,150	3,995	4,615	5,330	6,150	3,995	4,615

- Tension design strengths are based on the strength design provisions of ACI 318-11 Appendix D.
- Tabulated values are for a single anchor with no influence of another anchor.
- Interpolation between embedment depths is not permitted.
- Strength reduction factor, ϕ , is based on using a load combination from ACI 318-11 Section 9.2.
- The tension design strength listed for SDC (Seismic Design Category) A-B may also be used in SDC C-F when the tension component of the strength-level seismic design load on the anchor does not exceed 20% of the total factored tension load on the anchor associated with the same load combination.
- When designing anchorages in SDC C-F, the designer shall consider the ductility requirements of ACI 318-11 Section D.3.3.
- Tension design strengths in SDC C-F have been adjusted by 0.75 factor in accordance with ACI 318-11 Section D.3.3.4.4.

Carbon Steel Strong-Bolt® 2 Allowable Tension Loads
in Normal-Weight Concrete ($f'_c = 2,500$ psi) — Static Load

Anchor Dia. (in.)	Nominal Embed. Depth (in.)	Min. Concrete Thickness h_{min} (in.)	Critical Edge Distance c_{ac} (in.)	Minimum Edge Distance c_{min} (in.)	Allowable Tension Load (lb.)			
					Edge Distances = c_{ac} on all sides		Edge Distances = c_{min} on one side and c_{ac} on three sides	
					Uncracked	Cracked	Uncracked	Cracked
1/4	1 3/4	3 1/4	2 1/2	1 3/4	1,025	—	765	—
3/8	1 7/8	3 1/4	6 1/2	6	1,025	605	945	605
	2 7/8	4 1/2	6	6	1,550	1,290	1,550	1,290
1/2	2 3/4	4 1/2	7	7	1,680	1,330	1,680	1,330
	3 7/8	6	7 1/2	4	2,440	1,735	1,955	1,735
5/8	3 3/8	5 1/2	7 1/2	6 1/2	2,540	1,800	2,205	1,800
	5 1/8	7 7/8	9	6 1/2	4,190	3,200	3,870	3,200
3/4	4 1/8	6 3/4	9	6 1/2	3,305	2,445	2,495	2,445
	5 3/4	8 3/4	8	6 1/2	4,120	3,945	4,120	3,945
1	5 1/4	9	18	8	3,285	3,025	2,000	3,025
	9 3/4	13 1/2	13 1/2	8	3,805	4,395	3,805	4,395

- Allowable tension loads are calculated based on the strength design provision of ACI 318-11 Appendix D using a conversion factor of $\alpha = 1.4$. The conversion factor α is based on the load combination 1.2D + 1.6L assuming 50% dead load and 50% live load: $1.2(0.5) + 1.6(0.5) = 1.4$.
- Tabulated values are for a single anchor with no influence of another anchor.
- Interpolation between embedment depths is not permitted.

* See page 12 for an explanation of the load table icons.

Strong-Bolt® 2 Design Information — Concrete

Carbon Steel Strong-Bolt® 2 Allowable Tension Loads in Normal-Weight Concrete ($f'_c = 2,500$ psi) — Wind Load



Anchor Dia. (in.)	Nominal Embed. Depth (in.)	Min. Concrete Thickness h_{min} (in.)	Critical Edge Distance c_{ac} (in.)	Minimum Edge Distance c_{min} (in.)	Allowable Tension Load (lb.)			
					Edge Distances = c_{ac} on all sides		Edge Distances = c_{min} on one side and c_{ac} on three sides	
					Uncracked	Cracked	Uncracked	Cracked
1/4	1 3/4	3 1/4	2 1/2	1 3/4	860	—	640	—
3/8	1 7/8	3 1/4	6 1/2	6	860	505	795	505
	2 7/8	4 1/2	6	6	1,300	1,085	1,300	1,085
1/2	2 3/4	4 1/2	7	7	1,410	1,120	1,410	1,120
	3 7/8	6	7 1/2	4	2,050	1,460	1,645	1,460
5/8	3 3/8	5 1/2	7 1/2	6 1/2	2,135	1,510	1,850	1,510
	5 1/8	7 7/8	9	6 1/2	3,520	2,690	3,250	2,690
3/4	4 1/8	6 3/4	9	6 1/2	2,775	2,055	2,095	2,055
	5 3/4	8 3/4	8	6 1/2	3,460	3,315	3,460	3,315
1	5 1/4	9	18	8	2,760	2,540	1,680	2,540
	9 3/4	13 1/2	13 1/2	8	3,200	3,690	3,200	3,690

1. Allowable tension loads are calculated based on the strength design provision of ACI 318-11 Appendix D using a conversion factor of $\alpha = 1/6.6 = 1.67$. The conversion factor α is based on the load combination assuming 100% wind load.
2. Tabulated values are for a single anchor with no influence of another anchor.
3. Interpolation between embedment depths is not permitted.

Carbon Steel Strong-Bolt® 2 Allowable Tension Loads in Normal-Weight Concrete ($f'_c = 2,500$ psi) — Seismic Load



Anchor Dia. (in.)	Nominal Embed. Depth (in.)	Min. Concrete Thickness h_{min} (in.)	Critical Edge Distance c_{ac} (in.)	Minimum Edge Distance c_{min} (in.)	Allowable Tension Load (lb.)							
					Edge Distances = c_{ac} on all sides				Edge Distances = c_{min} on one side and c_{ac} on three sides			
					SDC A-B ⁴		SDC C-F ^{5,6}		SDC A-B ⁴		SDC C-F ^{5,6}	
					Uncracked	Cracked	Uncracked	Cracked	Uncracked	Cracked	Uncracked	Cracked
1/4	1 3/4	3 1/4	2 1/2	1 3/4	1,005	—	—	—	750	—	—	—
3/8	1 7/8	3 1/4	6 1/2	6	1,005	590	755	445	930	590	695	445
	2 7/8	4 1/2	6	6	1,520	1,265	1,140	950	1,520	1,265	1,140	950
1/2	2 3/4	4 1/2	7	7	1,645	1,305	1,230	980	1,645	1,305	1,230	980
	3 7/8	6	7 1/2	4	2,390	1,700	1,790	1,275	1,920	1,700	1,440	1,275
5/8	3 3/8	5 1/2	7 1/2	6 1/2	2,490	1,765	1,865	1,325	2,160	1,765	1,615	1,325
	5 1/8	7 7/8	9	6 1/2	4,105	3,135	3,080	2,350	3,795	3,135	2,845	2,350
3/4	4 1/8	6 3/4	9	6 1/2	3,240	2,400	2,430	1,800	2,445	2,400	1,835	1,800
	5 3/4	8 3/4	8	6 1/2	4,035	3,870	3,030	2,900	4,035	3,870	3,030	2,900
1	5 1/4	9	18	8	3,220	2,965	2,415	2,225	1,960	2,965	1,470	2,225
	9 3/4	13 1/2	13 1/2	8	3,730	4,305	2,795	3,230	3,730	4,305	2,795	3,230

1. Allowable tension loads are calculated based on the strength design provision of ACI 318-11 Appendix D using a conversion factor of $\alpha = 1/6.7 = 1.43$. The conversion factor α is based on the load combination assuming 100% seismic load.
2. Tabulated values are for a single anchor with no influence of another anchor.
3. Interpolation between embedment depths is not permitted.
4. The allowable tension load listed for SDC (Seismic Design Category) A-B may also be used in SDC C-F when the tension component of the strength-level seismic design load on the anchor does not exceed 20% of the total factored tension load on the anchor associated with the same load combination.
5. When designing anchorages in SDC C-F, the designer shall consider the ductility requirements of ACI 318-11 Section D.3.3.
6. Tension design strengths in SDC C-F have been adjusted by 0.75 factor in accordance with ACI 318-11 Section D.3.3.4.4.

C-A-2016 © 2015 SIMPSON STRONG-TIE COMPANY, INC.

Mechanical Anchors

* See page 12 for an explanation of the load table icons.

Strong-Bolt® 2 Design Information — Concrete



Stainless Steel Strong-Bolt® 2 Tension Design Strengths in Normal-Weight Concrete ($f'_c = 2,500$ psi)

Anchor Dia. (in.)	Nominal Embed. Depth (in.)	Min. Concrete Thickness h_{min} (in.)	Critical Edge Distance c_{ac} (in.)	Minimum Edge Distance c_{min} (in.)	Tension Design Strength (lb.)							
					Edge Distances = c_{ac} on all sides				Edge Distances = c_{min} on one side and c_{ac} on three sides			
					SDC A-B ⁵		SDC C-F ^{6,7}		SDC A-B ⁵		SDC C-F ^{6,7}	
					Uncracked	Cracked	Uncracked	Cracked	Uncracked	Cracked	Uncracked	Cracked
1/4	1 3/4	3 1/4	2 1/2	1 3/4	1,250	—	—	—	1,070	—	—	—
3/8	1 7/8	3 1/4	6 1/2	6	1,435	1,015	1,075	760	1,325	1,015	990	760
	2 7/8	4 1/2	8 1/2	6	3,085	2,045	2,090	1,380	2,175	2,045	1,630	1,380
1/2	2 3/4	4 1/2	6 1/2	6 1/2	2,100	1,665	1,575	1,250	2,100	1,665	1,575	1,250
	3 7/8	6	7	5	2,920	2,800	2,190	2,100	2,920	2,800	2,190	2,100
5/8	3 3/8	5 1/2	7 1/2	4	3,555	2,520	2,665	1,890	1,910	2,460	1,430	1,845
	5 1/8	7 7/8	9	4	4,950	4,255	3,710	3,190	3,905	3,685	2,925	2,765
3/4	4 1/8	6 3/4	8	6	4,835	3,425	3,625	2,570	3,625	3,425	2,720	2,570
	5 3/4	8 3/4	8	6	6,255	5,350	4,690	4,010	6,255	5,225	4,690	3,920

1. Tension design strengths are based on the strength design provisions of ACI 318-11 Appendix D.
2. Tabulated values are for a single anchor with no influence of another anchor.
3. Interpolation between embedment depths is not permitted.
4. Strength reduction factor, ϕ , is based on using a load combination from ACI 318-11 Section 9.2.
5. The tension design strength listed for SDC (Seismic Design Category) A-B may also be used in SDC C-F when the tension component of the strength-level seismic design load on the anchor does not exceed 20% of the total factored tension load on the anchor associated with the same load combination.
6. When designing anchorages in SDC C-F, the designer shall consider the ductility requirements of ACI 318-11 Section D.3.3.
7. Tension design strengths in SDC C-F have been adjusted by 0.75 factor in accordance with ACI 318-11 Section D.3.3.4.4.

Mechanical Anchors

Stainless Steel Strong-Bolt® 2 Allowable Tension Loads in Normal-Weight Concrete ($f'_c = 2,500$ psi) — Static Load



Anchor Dia. (in.)	Nominal Embed. Depth (in.)	Min. Concrete Thickness h_{min} (in.)	Critical Edge Distance c_{ac} (in.)	Minimum Edge Distance c_{min} (in.)	Allowable Tension Load (lb.)			
					Edge Distances = c_{ac} on all sides		Edge Distances = c_{min} on one side and c_{ac} on three sides	
					Uncracked	Cracked	Uncracked	Cracked
1/4	1 3/4	3 1/4	2 1/2	1 3/4	895	—	765	—
3/8	1 7/8	3 1/4	6 1/2	6	1,025	725	945	725
	2 7/8	4 1/2	8 1/2	6	2,205	1,460	1,555	1,460
1/2	2 3/4	4 1/2	6 1/2	6 1/2	1,500	1,190	1,500	1,190
	3 7/8	6	7	5	2,085	2,000	2,085	2,000
5/8	3 3/8	5 1/2	7 1/2	4	2,540	1,800	1,365	1,755
	5 1/8	7 7/8	9	4	3,535	3,040	2,790	2,630
3/4	4 1/8	6 3/4	8	6	3,455	2,445	2,590	2,445
	5 3/4	8 3/4	8	6	4,470	3,820	4,470	3,730

1. Allowable tension loads are calculated based on the strength design provision of ACI 318-11 Appendix D using a conversion factor of $\alpha = 1.4$. The conversion factor α is based on the load combination $1.2D + 1.6L$ assuming 50% dead load and 50% live load: $1.2(0.5) + 1.6(0.5) = 1.4$.
2. Tabulated values are for a single anchor with no influence of another anchor.
3. Interpolation between embedment depths is not permitted.

* See page 12 for an explanation of the load table icons.

Strong-Bolt® 2 Design Information — Concrete

Stainless Steel Strong-Bolt® 2 Allowable Tension Loads in Normal-Weight Concrete
($f'_c = 2,500$ psi) — Wind Load



Anchor Dia. (in.)	Nominal Embed. Depth (in.)	Min. Concrete Thickness h_{min} (in.)	Critical Edge Distance c_{ac} (in.)	Minimum Edge Distance c_{min} (in.)	Allowable Tension Load (lb.)			
					Edge Distances = c_{ac} on all sides		Edge Distances = c_{min} on one side and c_{ac} on three sides	
					Uncracked	Cracked	Uncracked	Cracked
1/4	1 3/4	3 1/4	2 1/2	1 3/4	750	—	640	—
3/8	1 7/8	3 1/4	6 1/2	6	860	610	795	610
	2 7/8	4 1/2	8 1/2	6	1,850	1,225	1,305	1,225
1/2	2 3/4	4 1/2	6 1/2	6 1/2	1,260	1,000	1,260	1,000
	3 3/8	6	7	5	1,750	1,680	1,750	1,680
5/8	3 3/8	5 1/2	7 1/2	4	2,135	1,510	1,145	1,475
	5 1/8	7 7/8	9	4	2,970	2,555	2,345	2,210
3/4	4 1/8	6 3/4	8	6	2,900	2,055	2,175	2,055
	5 3/4	8 3/4	8	6	3,755	3,210	3,755	3,135

1. Allowable tension loads are calculated based on the strength design provision of ACI 318-11 Appendix D using a conversion factor of $\alpha = 1/0.6 = 1.67$. The conversion factor α is based on the load combination assuming 100% wind load.
2. Tabulated values are for a single anchor with no influence of another anchor.
3. Interpolation between embedment depths is not permitted.

Stainless Steel Strong-Bolt® 2 Allowable Tension Loads in Normal-Weight Concrete
($f'_c = 2,500$ psi) — Seismic Load



Anchor Dia. (in.)	Nominal Embed. Depth (in.)	Min. Concrete Thickness h_{min} (in.)	Critical Edge Distance c_{ac} (in.)	Minimum Edge Distance c_{min} (in.)	Allowable Tension Load (lb.)							
					Edge Distances = c_{ac} on all sides				Edge Distances = c_{min} on one side and c_{ac} on three sides			
					SDC A-B ⁴		SDC C-F ^{5,6}		SDC A-B ⁴		SDC C-F ^{5,6}	
					Uncracked	Cracked	Uncracked	Cracked	Uncracked	Cracked	Uncracked	Cracked
1/4	1 3/4	3 1/4	2 1/2	1 3/4	875	—	—	—	750	—	—	—
3/8	1 7/8	3 1/4	6 1/2	6	1,005	710	755	530	930	710	695	530
	2 7/8	4 1/2	8 1/2	6	2,160	1,430	1,465	965	1,525	1,430	1,140	965
1/2	2 3/4	4 1/2	6 1/2	6 1/2	1,470	1,165	1,105	875	1,470	1,165	1,105	875
	3 3/8	6	7	5	2,045	1,960	1,535	1,470	2,045	1,960	1,535	1,470
5/8	3 3/8	5 1/2	7 1/2	4	2,490	1,765	1,865	1,325	1,335	1,720	1,000	1,290
	5 1/8	7 7/8	9	4	3,465	2,980	2,595	2,235	2,735	2,580	2,050	1,935
3/4	4 1/8	6 3/4	8	6	3,385	2,400	2,540	1,800	2,540	2,400	1,905	1,800
	5 3/4	8 3/4	8	6	4,380	3,745	3,285	2,805	4,380	3,660	3,285	2,745

1. Allowable tension loads are calculated based on the strength design provision of ACI 318-11 Appendix D using a conversion factor of $\alpha = 1/0.7 = 1.43$. The conversion factor α is based on the load combination assuming 100% seismic load.
2. Tabulated values are for a single anchor with no influence of another anchor.
3. Interpolation between embedment depths is not permitted.
4. The allowable tension load listed for SDC (Seismic Design Category) A-B may also be used in SDC C-F when the tension component of the strength-level seismic design load on the anchor does not exceed 20% of the total factored tension load on the anchor associated with the same load combination.
5. When designing anchorages in SDC C-F, the designer shall consider the ductility requirements of ACI 318-11 Section D.3.3.
6. Tension design strengths in SDC C-F have been adjusted by 0.75 factor in accordance with ACI 318-11 Section D.3.3.4.4.

C-A-2016 © 2015 SIMPSON STRONG-TIE COMPANY, INC.

Mechanical Anchors

* See page 12 for an explanation of the load table icons.

Strong-Bolt® 2 Design Information — Concrete

Carbon Steel Strong-Bolt® 2 Tension Design Strengths in Soffit of Normal-Weight or Sand-Lightweight Concrete-Filled Profile Steel Deck Assemblies ($f'_c = 3,000$ psi)



Anchor Dia. (in.)	Nominal Embed. Depth (in.)	Minimum End Distance c_{min} (in.)	Tension Design Strength (lb.)							
			Lower Flute				Upper Flute			
			SDC A-B ⁵		SDC C-F ^{6,7}		SDC A-B ⁵		SDC C-F ^{6,7}	
Uncracked	Cracked	Uncracked	Cracked	Uncracked	Cracked	Uncracked	Cracked			
3/8	2	3 1/4	1,145	675	860	505	1,480	870	1,110	655
	3 3/8	6	2,050	1,700	1,535	1,275	—	—	—	—
1/2	2 3/4	4 1/2	1,675	1,325	1,260	995	3,115	2,460	2,340	1,845
	4 1/2	8	2,495	1,775	1,870	1,330	—	—	—	—
5/8	3 3/8	5 1/2	2,395	1,700	1,795	1,275	—	—	—	—
	5 5/8	10	4,265	3,245	3,200	2,435	—	—	—	—
3/4	4 1/8	6 3/4	2,470	1,830	1,855	1,370	—	—	—	—

1. Tension design strengths are based on the strength design provisions of ACI 318-11 Appendix D.
2. Tabulated values are for a single anchor with no influence of another anchor.
3. Interpolation between embedment depths is not permitted.
4. Strength reduction factor, ϕ , is based on using a load combination from ACI 318-11 Section 9.2.
5. The tension design strength listed for SDC (Seismic Design Category) A-B may also be used in SDC C-F when the tension component of the strength-level seismic design load on the anchor does not exceed 20% of the total factored tension load on the anchor associated with the same load combination.
6. When designing anchorages in SDC C-F, the designer shall consider the ductility requirements of ACI 318-11 Section D.3.3.
7. Tension design strengths in SDC C-F have been adjusted by 0.75 factor in accordance with ACI 318-11 Section D.3.3.4.4.
8. Installation must comply with Figure 2 on page 152.

Carbon Steel Strong-Bolt® 2 Allowable Tension Loads in Soffit of Normal-Weight or Sand-Lightweight Concrete-Filled Profile Steel Deck Assemblies ($f'_c = 3,000$ psi) — Static Load



Anchor Dia. (in.)	Nominal Embed. Depth (in.)	Minimum End Distance c_{min} (in.)	Allowable Tension Load (lb.)			
			Lower Flute		Upper Flute	
			Uncracked	Cracked	Uncracked	Cracked
3/8	2	3 1/4	820	480	1,055	620
	3 3/8	6	1,465	1,215	—	—
1/2	2 3/4	4 1/2	1,195	945	2,225	1,755
	4 1/2	8	1,780	1,270	—	—
5/8	3 3/8	5 1/2	1,710	1,215	—	—
	5 5/8	10	3,045	2,320	—	—
3/4	4 1/8	6 3/4	1,765	1,305	—	—

1. Allowable tension loads are calculated based on the strength design provision of ACI 318-11 Appendix D using a conversion factor of $\alpha = 1.4$. The conversion factor α is based on the load combination $1.2D + 1.6L$ assuming 50% dead load and 50% live load: $1.2(0.5) + 1.6(0.5) = 1.4$.
2. Tabulated values are for a single anchor with no influence of another anchor.
3. Interpolation between embedment depths is not permitted.
4. Installation must comply with Figure 2 on page 152.

* See page 12 for an explanation of the load table icons.

Strong-Bolt® 2 Design Information — Concrete

Carbon Steel Strong-Bolt® 2 Allowable Tension Loads in Soffit of Normal-Weight or Sand-Lightweight Concrete-Filled Profile Steel Deck Assemblies ($f'_c = 3,000$ psi) — Wind Load



Anchor Dia. (in.)	Nominal Embed. Depth (in.)	Minimum End Distance c_{min} (in.)	Allowable Tension Load (lb.)			
			Lower Flute		Upper Flute	
			Uncracked	Cracked	Uncracked	Cracked
3/8	2	3 1/4	685	405	890	520
	3 3/8	6	1,230	1,020	—	—
1/2	2 3/4	4 1/2	1,005	795	1,870	1,475
	4 1/2	8	1,495	1,065	—	—
5/8	3 3/8	5 1/2	1,435	1,020	—	—
	5 5/8	10	2,560	1,945	—	—
3/4	4 1/8	6 3/4	1,480	1,100	—	—

1. Allowable tension loads are calculated based on the strength design provision of ACI 318-11 Appendix D using a conversion factor of $\alpha = 1/1.67 = 0.6$. The conversion factor α is based on the load combination assuming 100% wind load.
2. Tabulated values are for a single anchor with no influence of another anchor.
3. Interpolation between embedment depths is not permitted.
4. Installation must comply with Figure 2 on page 152.

Carbon Steel Strong-Bolt® 2 Allowable Tension Loads in Soffit of Normal-Weight or Sand-Lightweight Concrete-Filled Profile Steel Deck Assemblies ($f'_c = 3,000$ psi) — Seismic Load



Anchor Dia. (in.)	Nominal Embed. Depth (in.)	Minimum End Distance c_{min} (in.)	Allowable Tension Load (lb.)							
			Lower Flute				Upper Flute			
			SDC A-B ⁴		SDC C-F ^{5,6}		SDC A-B ⁴		SDC C-F ^{5,6}	
			Uncracked	Cracked	Uncracked	Cracked	Uncracked	Cracked	Uncracked	Cracked
3/8	2	3 1/4	800	475	600	355	1,035	610	775	460
	3 3/8	6	1,435	1,190	1,075	895	—	—	—	—
1/2	2 3/4	4 1/2	1,175	930	880	695	2,180	1,720	1,640	1,290
	4 1/2	8	1,745	1,245	1,310	930	—	—	—	—
5/8	3 3/8	5 1/2	1,675	1,190	1,255	895	—	—	—	—
	5 5/8	10	2,985	2,270	2,240	1,705	—	—	—	—
3/4	4 1/8	6 3/4	1,730	1,280	1,300	960	—	—	—	—

1. Allowable tension loads are calculated based on the strength design provision of ACI 318-11 Appendix D using a conversion factor of $\alpha = 1/1.43 = 0.7$. The conversion factor α is based on the load combination assuming 100% seismic load.
2. Tabulated values are for a single anchor with no influence of another anchor.
3. Interpolation between embedment depths is not permitted.
4. The allowable tension load listed for SDC (Seismic Design Category) A-B may also be used in SDC C-F when the tension component of the strength-level seismic design load on the anchor does not exceed 20% of the total factored tension load on the anchor associated with the same load combination.
5. When designing anchorages in SDC C-F, the designer shall consider the ductility requirements of ACI 318-11 Section D.3.3.
6. Tension design strengths in SDC C-F have been adjusted by 0.75 factor in accordance with ACI 318-11 Section D.3.3.4.4.
7. Installation must comply with Figure 2 on page 152.

* See page 12 for an explanation of the load table icons.

Strong-Bolt® 2 Design Information — Concrete

Stainless Steel Strong-Bolt® 2 Tension Design Strengths in Soffit of Normal-Weight or Sand-Lightweight Concrete-Filled Profile Steel Deck Assemblies ($f'_c = 3,000$ psi)

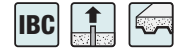

Anchor Dia. (in.)	Nominal Embed. Depth (in.)	Minimum End Distance c_{min} (in.)	Tension Design Strength (lb.)							
			Lower Flute				Upper Flute			
			SDC A-B ⁵		SDC C-F ^{6,7}		SDC A-B ⁵		SDC C-F ^{6,7}	
Uncracked	Cracked	Uncracked	Cracked	Uncracked	Cracked	Uncracked	Cracked			
3/8	2	3 1/4	1,025	800	770	600	1,295	1,010	970	755
	3 3/8	6	2,570	1,695	1,735	1,145	—	—	—	—
1/2	2 3/4	4 1/2	1,610	1,295	1,205	970	1,665	1,335	1,250	1,000
	4 1/2	8	1,730	1,660	1,295	1,245	—	—	—	—
5/8	3 3/8	5 1/2	1,605	1,135	1,205	855	—	—	—	—
	5 5/8	10	3,250	2,615	2,440	1,960	—	—	—	—
3/4	4 1/8	6 3/4	2,780	1,970	2,085	1,475	—	—	—	—

1. Tension design strengths are based on the strength design provisions of ACI 318-11 Appendix D.
2. Tabulated values are for a single anchor with no influence of another anchor.
3. Interpolation between embedment depths is not permitted.
4. Strength reduction factor, ϕ , is based on using a load combination from ACI 318-11 Section 9.2.
5. The tension design strength listed for SDC (Seismic Design Category) A-B may also be used in SDC C-F when the tension component of the strength-level seismic design load on the anchor does not exceed 20% of the total factored tension load on the anchor associated with the same load combination.
6. When designing anchorages in SDC C-F, the designer shall consider the ductility requirements of ACI 318-11 Section D.3.3.
7. Tension design strengths in SDC C-F have been adjusted by 0.75 factor in accordance with ACI 318-11 Section D.3.3.4.4.
8. Installation must comply with Figure 2 on page 152.

Stainless Steel Strong-Bolt® 2 Allowable Tension Loads in Soffit of Normal-Weight or Sand-Lightweight Concrete-Filled Profile Steel Deck Assemblies ($f'_c = 3,000$ psi) — Static Load



Anchor Dia. (in.)	Nominal Embed. Depth (in.)	Minimum End Distance c_{min} (in.)	Allowable Tension Load (lb.)			
			Lower Flute		Upper Flute	
			Uncracked	Cracked	Uncracked	Cracked
3/8	2	3 1/4	730	570	925	720
	3 3/8	6	1,835	1,210	—	—
1/2	2 3/4	4 1/2	1,150	925	1,190	955
	4 1/2	8	1,235	1,185	—	—
5/8	3 3/8	5 1/2	1,145	810	—	—
	5 5/8	10	2,320	1,870	—	—
3/4	4 1/8	6 3/4	1,985	1,405	—	—

1. Allowable tension loads are calculated based on the strength design provision of ACI 318-11 Appendix D using a conversion factor of $\alpha = 1.4$. The conversion factor α is based on the load combination 1.2D + 1.6L assuming 50% dead load and 50% live load: $1.2(0.5) + 1.6(0.5) = 1.4$.
2. Tabulated values are for a single anchor with no influence of another anchor.
3. Interpolation between embedment depths is not permitted.
4. Installation must comply with Figure 2 on page 152.

* See page 12 for an explanation of the load table icons.

Strong-Bolt® 2 Design Information — Concrete

Stainless Steel Strong-Bolt® 2 Allowable Tension Loads in Soffit of Normal-Weight or Sand-Lightweight Concrete-Filled Profile Steel Deck Assemblies ($f'_c = 3,000$ psi) — Wind Load



Anchor Dia. (in.)	Nominal Embed. Depth (in.)	Minimum End Distance c_{min} (in.)	Allowable Tension Load (lb.)			
			Lower Flute		Upper Flute	
			Uncracked	Cracked	Uncracked	Cracked
3/8	2	3 1/4	615	480	775	605
	3 3/8	6	1,540	1,015	—	—
1/2	2 3/4	4 1/2	965	775	1,000	800
	4 1/2	8	1,040	995	—	—
5/8	3 3/8	5 1/2	965	680	—	—
	5 5/8	10	1,950	1,570	—	—
3/4	4 1/8	6 3/4	1,670	1,180	—	—

1. Allowable tension loads are calculated based on the strength design provision of ACI 318-11 Appendix D using a conversion factor of $\alpha = 1/0.6 = 1.67$. The conversion factor α is based on the load combination assuming 100% wind load.
2. Tabulated values are for a single anchor with no influence of another anchor.
3. Interpolation between embedment depths is not permitted.
4. Installation must comply with Figure 2 on page 152.

Stainless Steel Strong-Bolt® 2 Allowable Tension Loads in Soffit of Normal-Weight or Sand-Lightweight Concrete-Filled Profile Steel Deck Assemblies ($f'_c = 3,000$ psi) — Seismic Load



Anchor Dia. (in.)	Nominal Embed. Depth (in.)	Minimum End Distance c_{min} (in.)	Allowable Tension Load (lb.)							
			Lower Flute				Upper Flute			
			SDC A-B ⁴		SDC C-F ^{5,6}		SDC A-B ⁴		SDC C-F ^{5,6}	
Uncracked	Cracked	Uncracked	Cracked	Uncracked	Cracked	Uncracked	Cracked	Uncracked	Cracked	
3/8	2	3 1/4	720	560	540	420	905	705	680	530
	3 3/8	6	1,800	1,185	1,215	800	—	—	—	—
1/2	2 3/4	4 1/2	1,125	905	845	680	1,165	935	875	700
	4 1/2	8	1,210	1,160	905	870	—	—	—	—
5/8	3 3/8	5 1/2	1,125	795	845	600	—	—	—	—
	5 5/8	10	2,275	1,830	1,710	1,370	—	—	—	—
3/4	4 1/8	6 3/4	1,945	1,380	1,460	1,035	—	—	—	—

1. Allowable tension loads are calculated based on the strength design provision of ACI 318-11 Appendix D using a conversion factor of $\alpha = 1/0.7 = 1.43$. The conversion factor α is based on the load combination assuming 100% seismic load.
2. Tabulated values are for a single anchor with no influence of another anchor.
3. Interpolation between embedment depths is not permitted.
4. The allowable tension load listed for SDC (Seismic Design Category) A-B may also be used in SDC C-F when the tension component of the strength-level seismic design load on the anchor does not exceed 20% of the total factored tension load on the anchor associated with the same load combination.
5. When designing anchorages in SDC C-F, the designer shall consider the ductility requirements of ACI 318-11 Section D.3.3.
6. Tension design strengths in SDC C-F have been adjusted by 0.75 factor in accordance with ACI 318-11 Section D.3.3.4.4.
7. Installation must comply with Figure 2 on page 152.

* See page 12 for an explanation of the load table icons.

Strong-Bolt® 2 Design Information — Masonry

Carbon-Steel Strong-Bolt® 2 Tension and Shear Loads in 8" Lightweight, Medium-Weight and Normal-Weight Grout-Filled CMU



Size in. (mm)	Drill Bit Dia. (in.)	Min. Embed. Depth in. (mm)	Install. Torque ft.-lb. (N-m)	Critical Edge Dist. in. (mm)	Critical End Dist. in. (mm)	Critical Spacing in. (mm)	Tension Load		Shear Load	
							Ultimate lb. (kN)	Allowable lb. (kN)	Ultimate lb. (kN)	Allowable lb. (kN)
Anchor Installed in the Face of the CMU Wall (See Figure 1)										
1/4 (6.4)	1/4	1 3/4 (45)	4 (5.4)	12 (305)	12 (305)	8 (203)	1,150 (5.1)	230 (1.0)	1,500 (6.7)	300 (1.3)
3/8 (9.5)	3/8	2 5/8 (67)	20 (27.1)	12 (305)	12 (305)	8 (203)	2,185 (9.7)	435 (1.9)	3,875 (17.2)	775 (3.4)
1/2 (12.7)	1/2	3 1/2 (89)	35 (47.5)	12 (305)	12 (305)	8 (203)	2,645 (11.8)	530 (2.4)	5,055 (22.5)	1,010 (4.5)
5/8 (15.9)	5/8	4 3/8 (111)	55 (74.6)	20 (508)	20 (508)	8 (203)	4,460 (19.8)	890 (4.0)	8,815 (39.2)	1,765 (7.9)
3/4 (19.1)	3/4	5 1/4 (133)	100 (135.6)	20 (508)	20 (508)	8 (203)	5,240 (23.3)	1,050 (4.7)	12,450 (55.4)	2,490 (11.1)

- The tabulated allowable loads are based on a safety factor of 5.0 for installation under the IBC and IRC.
- Listed loads may be applied to installations on the face of the CMU wall at least 1 1/4 inch away from headjoints.
- Values for 8-inch-wide concrete masonry units (CMU) with a minimum specified compressive strength of masonry, f'_m , at 28 days is 1,500 psi.
- Embedment depth is measured from the outside face of the concrete masonry unit.
- Tension and shear loads may be combined using the parabolic interaction equation ($n = 5/8$).
- Refer to allowable load adjustment factors for edge distance and spacing on page 163.
- Allowable loads may be increased 33 1/3% for short-term loading due to wind forces or seismic forces where permitted by code.

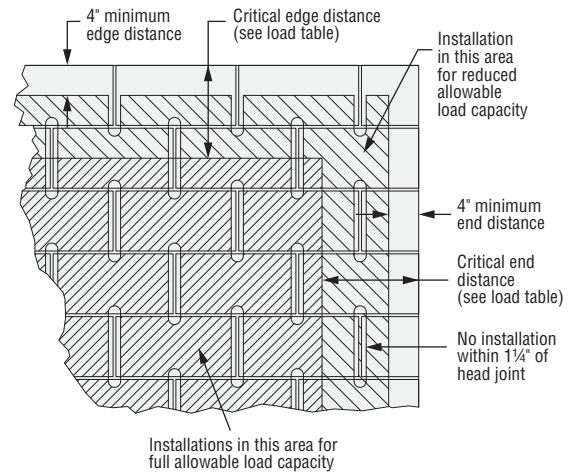

Figure 1

Carbon-Steel Strong-Bolt® 2 Tension and Shear Loads in 8" Lightweight, Medium-weight and Normal-Weight Grout-Filled CMU



Size in. (mm)	Drill Bit Dia. in.	Min. Embed. Depth in. (mm)	Install. Torque ft.-lb. (N-m)	Min. Edge Dist. in. (mm)	Critical End Dist. in. (mm)	Critical Spacing in. (mm)	Tension Load		Shear Load Perp. To Edge		Shear Load Parallel To Edge	
							Ultimate lb. (kN)	Allowable lb. (kN)	Ultimate lb. (kN)	Allowable lb. (kN)	Ultimate lb. (kN)	Allowable lb. (kN)
Anchor Installed in Cell Opening or Web (Top of Wall) (See Figure 2)												
1/2 (12.7)	1/2	3 1/2 (89)	35 (47.5)	1 3/4 (45)	12 (305)	8 (203)	2,080 (9.3)	415 (1.8)	1,165 (5.2)	235 (1.0)	3,360 (14.9)	670 (3.0)
5/8 (15.9)	5/8	4 3/8 (111)	55 (74.6)	1 3/4 (45)	12 (305)	8 (203)	3,200 (14.2)	640 (2.8)	1,370 (6.1)	275 (1.2)	3,845 (17.1)	770 (3.4)

- The tabulated allowable loads are based on a safety factor of 5.0 for installation under the IBC and IRC.
- Values for 8-inch-wide concrete masonry units (CMU) with a minimum specified compressive strength of masonry, f'_m , at 28 days is 1,500 psi.
- Tension and shear loads may be combined using the parabolic interaction equation ($n = 5/8$).
- Refer to allowable load adjustment factors for edge distance and spacing on page 163.
- Allowable loads may be increased 33 1/3% for short-term loading due to wind forces or seismic forces where permitted by code.

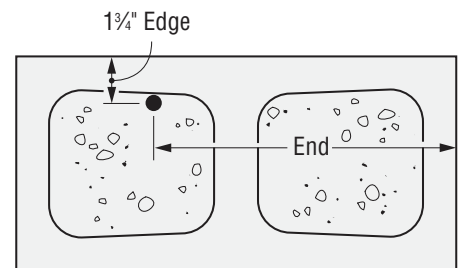

Figure 2

* See page 12 for an explanation of the load table icons.

Strong-Bolt® 2 Design Information — Masonry

Carbon-Steel Strong-Bolt® 2 Allowable Load Adjustment Factors for Face-of-Wall Installation in 8" Grout-Filled CMU: Edge Distance and Spacing, Tension and Shear Loads

How to use these charts:

- The following tables are for reduced edge distance and spacing.
- Locate the anchor size to be used for either a tension and/or shear load application.
- Locate the embedment (E) at which the anchor is to be installed.
- Locate the edge distance (c_{act}) or spacing (s_{act}) at which the anchor is to be installed.
- The load adjustment factor (f_c or f_s) is the intersection of the row and column.
- Multiply the allowable load by the applicable load adjustment factor.
- Reduction factors for multiple edges or spacings are multiplied together.

Edge or End Distance Tension (f_c)

c_{act} (in.)	Dia.	¼	⅜	½	⅝	¾	IBC*
	E	1¼	2⅝	3½	4⅞	5¼	
	c_{cr}	12	12	12	20	20	
	c_{min}	2	4	4	4	4	
	f_{cmin}	1.00	1.00	1.00	1.00	0.97	
2		1.00					
4		1.00	1.00	1.00	1.00	0.97	
6		1.00	1.00	1.00	1.00	0.97	
8		1.00	1.00	1.00	1.00	0.98	
10		1.00	1.00	1.00	1.00	0.98	
12		1.00	1.00	1.00	1.00	0.99	
14					1.00	0.99	
16					1.00	0.99	
18					1.00	1.00	
20					1.00	1.00	

Edge or End Distance Shear (f_c)

c_{act} (in.)	Dia.	¼	⅜	½	⅝	¾	IBC*
	E	1¼	2⅝	3½	4⅞	5¼	
	c_{cr}	12	12	12	20	20	
	c_{min}	2	4	4	4	4	
	f_{cmin}	0.88	0.71	0.60	0.36	0.28	
2		0.88					
4		0.90	0.71	0.60	0.36	0.28	
6		0.93	0.78	0.70	0.44	0.37	
8		0.95	0.86	0.80	0.52	0.46	
10		0.98	0.93	0.90	0.60	0.55	
12		1.00	1.00	1.00	0.68	0.64	
14					0.76	0.73	
16					0.84	0.82	
18					0.92	0.91	
20					1.00	1.00	

Spacing Tension (f_s)

s_{act} (in.)	Dia.	¼	⅜	½	⅝	¾	IBC*
	E	1¼	2⅝	3½	4⅞	5¼	
	s_{cr}	8	8	8	8	8	
	s_{min}	4	4	4	4	4	
	f_{smin}	1.00	1.00	0.93	0.86	0.80	
4		1.00	1.00	0.93	0.86	0.80	
6		1.00	1.00	0.97	0.93	0.90	
8		1.00	1.00	1.00	1.00	1.00	

Spacing Shear (f_s)

s_{act} (in.)	Dia.	¼	⅜	½	⅝	¾	IBC*
	E	1¼	2⅝	3½	4⅞	5¼	
	s_{cr}	8	8	8	8	8	
	s_{min}	4	4	4	4	4	
	f_{smin}	1.00	1.00	1.00	1.00	1.00	
4		1.00	1.00	1.00	1.00	1.00	
6		1.00	1.00	1.00	1.00	1.00	
8		1.00	1.00	1.00	1.00	1.00	

Load Adjustment Factors for Carbon-Steel Strong-Bolt® 2 Wedge Anchors in Top-of-Wall Installation in 8" Grout-Filled CMU: Edge Distance and Spacing, Tension and Shear Loads

End Distance Tension (f_c)

s_{act} (in.)	Dia.	½	⅝	IBC*
	E	3½	4⅞	
	c_{cr}	12	12	
	c_{min}	4	4	
	f_{cmin}	1.00	1.00	
4		1.00	1.00	
6		1.00	1.00	
8		1.00	1.00	
10		1.00	1.00	
12		1.00	1.00	

End Distance Shear Perpendicular to Edge (f_c)

c_{act} (in.)	Dia.	½	⅝	IBC*
	E	3½	4⅞	
	c_{cr}	12	12	
	c_{min}	4	4	
	f_{cmin}	0.90	0.83	
4		0.90	0.83	
6		0.93	0.87	
8		0.95	0.92	
10		0.98	0.96	
12		1.00	1.00	

End Distance Shear Parallel to Edge (f_c)

c_{act} (in.)	Dia.	½	⅝	IBC*
	E	3½	4⅞	
	c_{cr}	12	12	
	c_{min}	4	4	
	f_{cmin}	0.53	0.50	
4		0.53	0.50	
6		0.65	0.63	
8		0.77	0.75	
10		0.88	0.88	
12		1.00	1.00	

Spacing Tension (f_s)

s_{act} (in.)	Dia.	½	⅝	IBC*
	E	3½	4⅞	
	s_{cr}	8	8	
	s_{min}	4	4	
	f_{smin}	0.93	0.86	
4		0.93	0.86	
6		0.97	0.93	
8		1.00	1.00	

Spacing Shear Perpendicular or Parallel to Edge (f_s)

s_{act} (in.)	Dia.	½	⅝	IBC*
	E	3½	4⅞	
	s_{cr}	8	8	
	s_{min}	4	4	
	f_{smin}	1.00	1.00	
4		1.00	1.00	
6		1.00	1.00	
8		1.00	1.00	

For footnotes, please see page 200.

* See page 12 for an explanation of the load table icons.